

Design of a Compact Planar Rogowski Coil Current Sensor

This paper investigates the utilization of a planar Rogowski coil located between the dc-bus traces and the dc-link capacitor and half-bridge to measure the half-bridge's switch node output current and switch transient current. The sensor fundamentals are explained in detail, and design considerations for the current sensor's integrator are derived. The newly proposed simplified integrator design no longer requires a reset switch and potentiometer, thus greatly increasing its usability for high-volume productions and reducing costs. Fig. 1 shows the equivalent electric circuit of the planar Rogowski coil current sensor. The Rogowski coil has two mutual inductances; one is coupled to the $dc +$ trace (M_{dc+}), and the other mutual inductance couples to the $dc -$ trace (M_{dc-}). The integrator circuit is depicted in the right half of the figure. By reducing the integrator gain at low frequencies, the op-amp's input offset voltage no longer causes the integration capacitance to charge up. Thus, the output voltage (V_{out}) doesn't diverge to the supply rails of the op-amp, allowing the removal of the previously required reset switch and potentiometer. A compact current sensor prototype is designed for a SiC MOSFET half-bridge application. The prototype sensor has a total size of 2.95 cm^2 .

The sensor is evaluated for its switch transient current measurement performance. It is compared to a commercial Rogowski coil. Double pulse tests are carried out at a dc-bus voltage of 160 V and a drain current of 42 A . The double pulse measurement results are shown in Fig. 2. High-speed switching transient currents are measured accurately. The output impedance of the Rogowski coil is measured with a 3 GHz impedance analyzer. The measured maximum bandwidth of the Rogowski coil is 283 MHz .

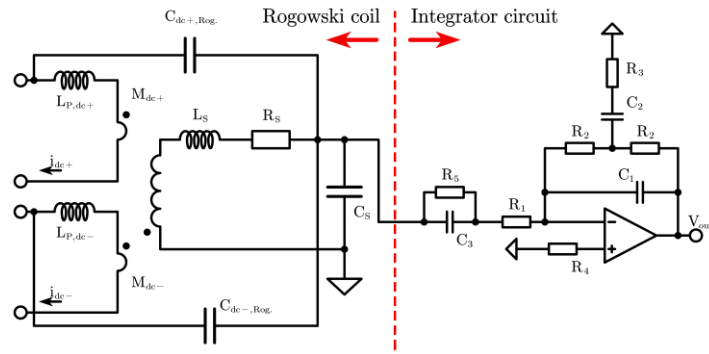

Fig. 1. Equivalent electric circuit of the planar Rogowski coil current sensor

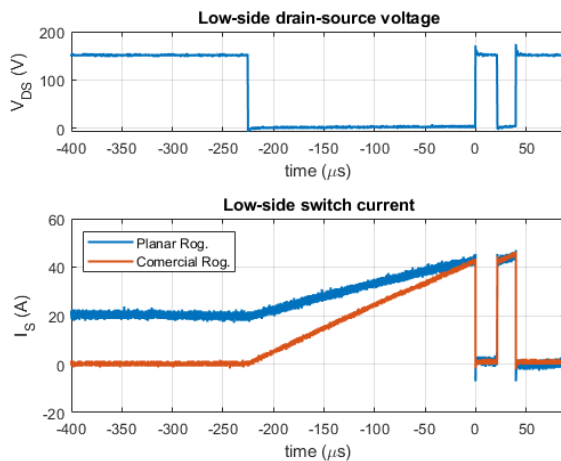

Fig. 2. Double pulse measurement and current comparison of commercial Rogowski coil and planar Rogowski coil